

451
Industrial Flashlight



Specifications

Designation: Industrial Flashlight
Power Source: One Lantern Battery
 Spring Terminals
 (ANSI/NEDA 908 Series)
Lamp: No. PR-13
 (Rated at 4.75V, 0.5A)
 No. KPR-113
 (Rated at 4.8V, 0.75A)
Lamp Life: Rated at 15 Hours (PR-13)
 Rated at 20 Hours (KPR-113)
Lamp Output: 28.5 Lumens (PR-13)
 51 Lumens (KPR-113)
Typical Weight: 475 grams (16.8 oz.)
 (without battery)

Features

Floating Lantern
 Large Reflector for Bright Beam
 Weatherproof

Typical Battery Service

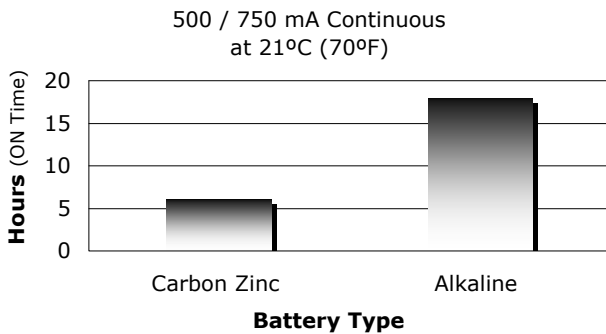

Physical Dimensions

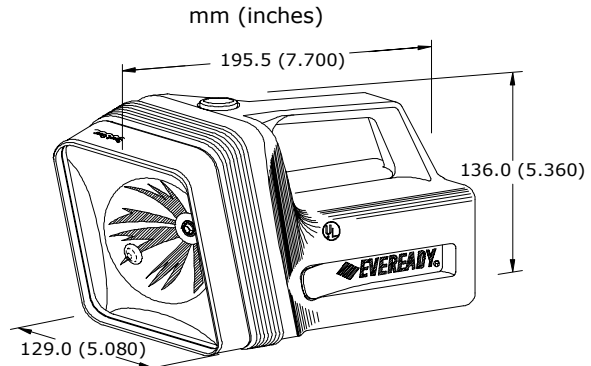

Typical Battery Service to 3.6V at 21°C (70°F)

ANSI Lighting Test	Battery Type	Hours (ON Time)
PR13 = 500 mA Continuous	1209	6.0
KPR-113 = 750 mA Continuous	529	18

Important Notice

This datasheet contains information specific to flashlights manufactured at the time of its publication.

Contents herein do not constitute a warranty.

Copyright Eveready Battery Co. Inc. - All Rights Reserved